

# Tech Notes

Vol.1 Issue 2 (3 pages)

## Expansion/Contraction due to Temperature Change

Composite Lumber is made from recycled or virgin plastic and natural fibers. In general, the expansion and contraction of composite lumber are greater than wood. Longer boards will experience a greater amount of dimension change than shorter boards; therefore, if possible, it is a good idea to avoid end butting boards of 20 feet in length end to end. You can design your deck with different levels (elevations); thereby, eliminating any end to end joints. Another alternative is to build a deck with Herringbone pattern (see Contractor's Handbook 2003.V3 page 6). If this is unavoidable, please plan your butt joints.

A consistent pattern like this picture has great advantages:

- 1). It is recommended to double the joists for stronger support, allow more fastening surface and ensure screws are fastened at least  $\frac{3}{4}$ " from each end of the Nexwood boards.
- 2). With this staggered pattern, lumber can be used with little waste.
- 3). It has a clean, finished appearance.

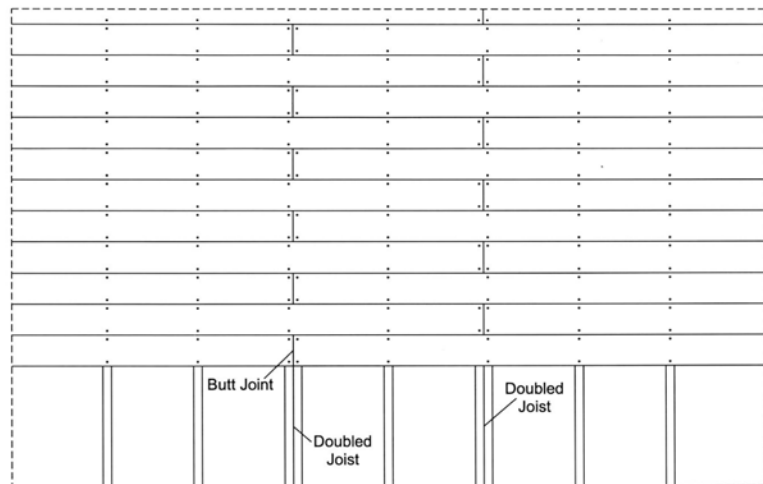

## How to reduce the chance of gapping / shrinking?

Properly fastening screws will hold boards from moving drastically due to the expansion/contraction during temperature fluctuations. However, some movements may happen, but the direction is unpredictable and gapping can be expected.

## To reduce the chance of gapping:

- Try to avoid abutment patterns especially for long boards (20 ft).
- The ideal temperature to install your deck is between 70<sup>o</sup>-80<sup>o</sup> F and anticipate the highest and lowest temperature in your area. Avoid installation under extremely cold or hot weather.
- Fasten the boards with proper screws in every joist. Use recommended screws, install as recommended by following our instruction manual.
- If you use a Shadoe Track or Deckmaster system, we suggest using two tracks for each joist (left and right) and applying screws in all holes. Use double joist for butt joint.

## Cause of unpredictable direction of gapping:

Some of your customers commented that the boards shrank, and the boards could not move back to original positions. In reality, the board will not shrink, it will come back to previous length if the temperature increases. Due to temperature changes, we cannot predict the movement of the boards. The boards will move (expand/contract) in the direction of least resistance or be held by the fasteners. If the screws move/bend, sometimes the boards will not come back to the previous position.

## Details of double joist for butt joint:

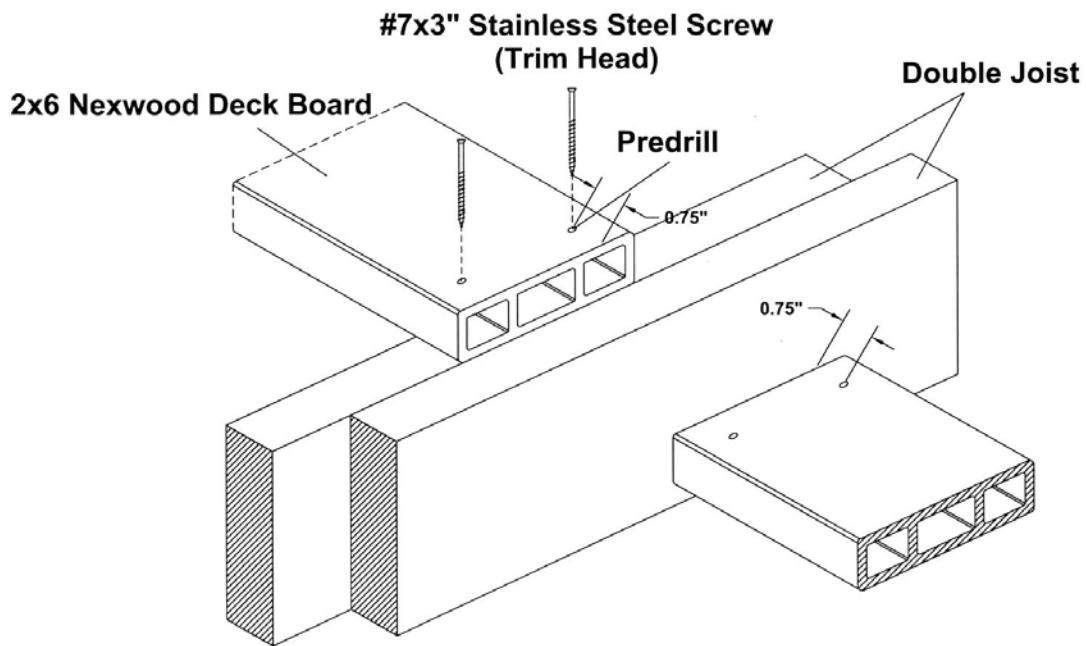

**2x6 Nexwood Butt Joint**

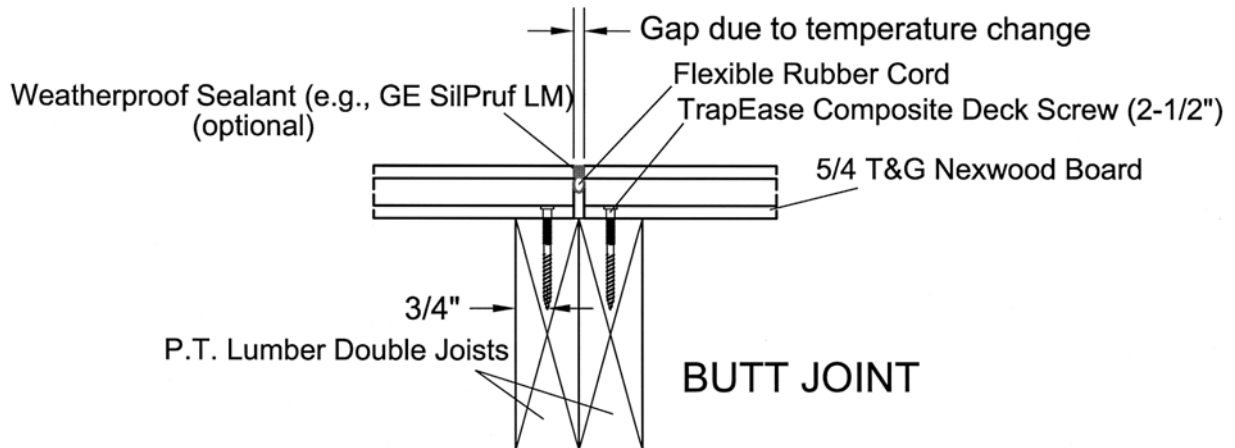
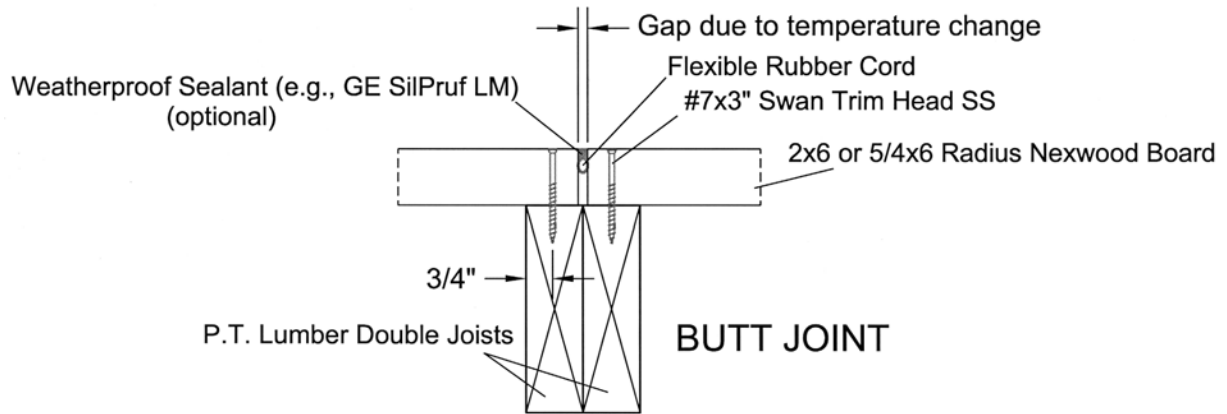

Nexwood — Keeping you informed  
 Nexwood Industries Limited - [www.nexwood.com](http://www.nexwood.com)